

ASZ-800 Series Retraction Device for Furnace Probes

FUNCTIONALITY

The retraction devices of the ASZ-800 series serve to protect the furnace probes used for combustion chamber interior observations. In case of malfunctions, the probe is automatically moved out of the furnace by the retraction device; the furnace opening is sealed by the forced actuated shutter. These measures prevent damage to the probe, camera and lens due over-heating. The pneumatically controlled retraction devices of the ASZ-800 series have the following main functions:

- Fully automatic extension of a furnace probe from the combustion chamber in case of failure of cooling media, compressed air or mains voltage
- Service-friendly, manual movement of the probe for cost-effective maintenance work without assembly effort for removal and installation
- Adjustment of mounting position and viewing angle remain unchanged

KEY FEATURES

- Pneumatically controlled linear actuator
- Variable probe installation depths, position-independent installation
- Forced actuated shutter
- Corrosion-resistant
- Different stroke lengths available
- Default designed for probe diameters for 70mm and 104 mm
- Optional 360° rotatable probe

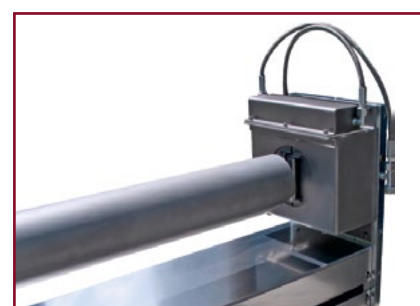
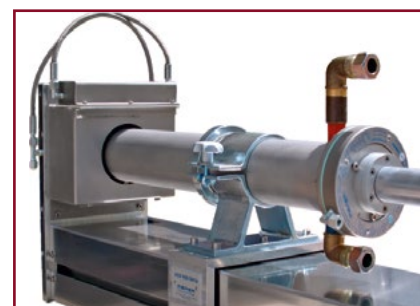

ASZ-SERIE - TECHNICAL DATA

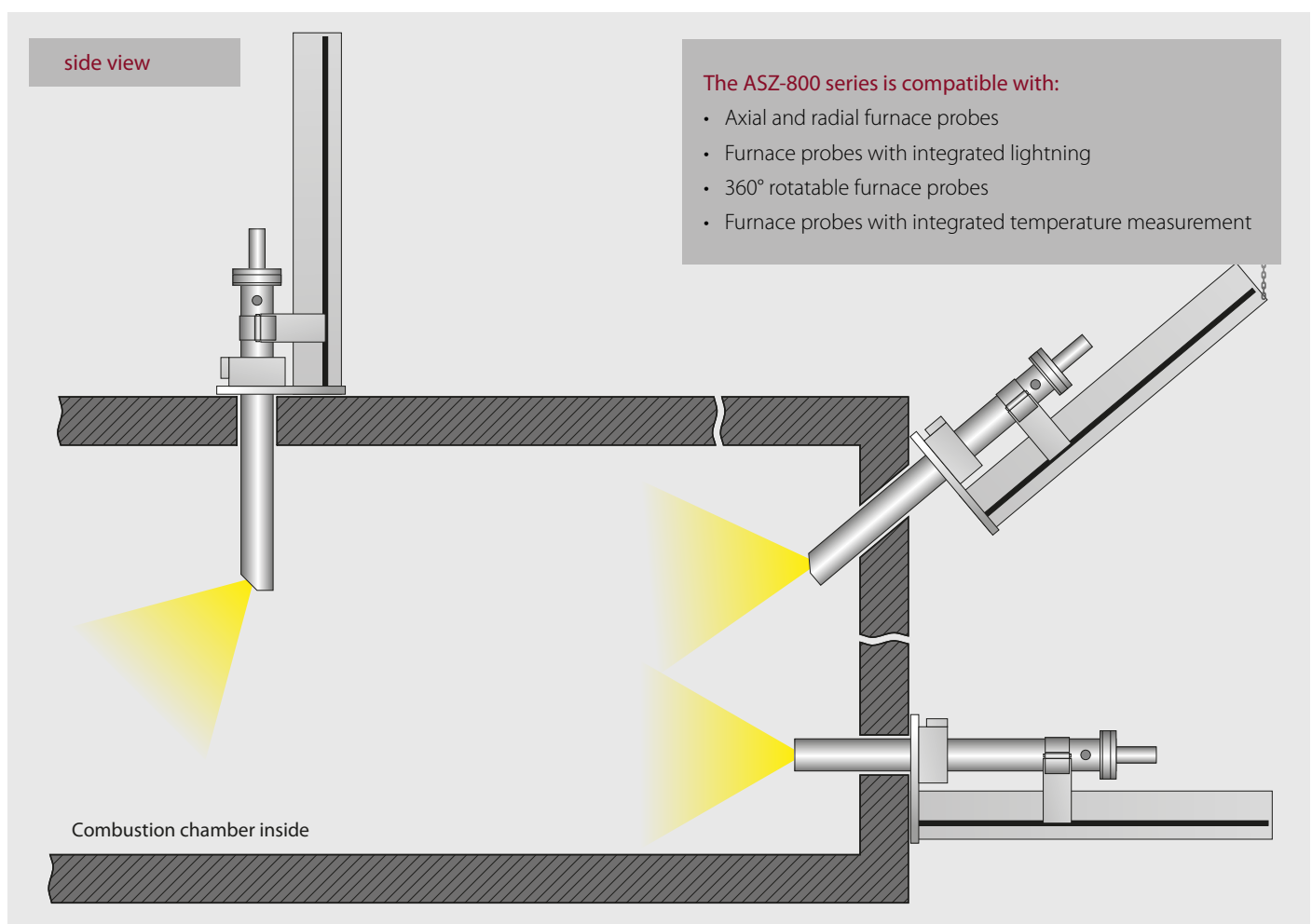
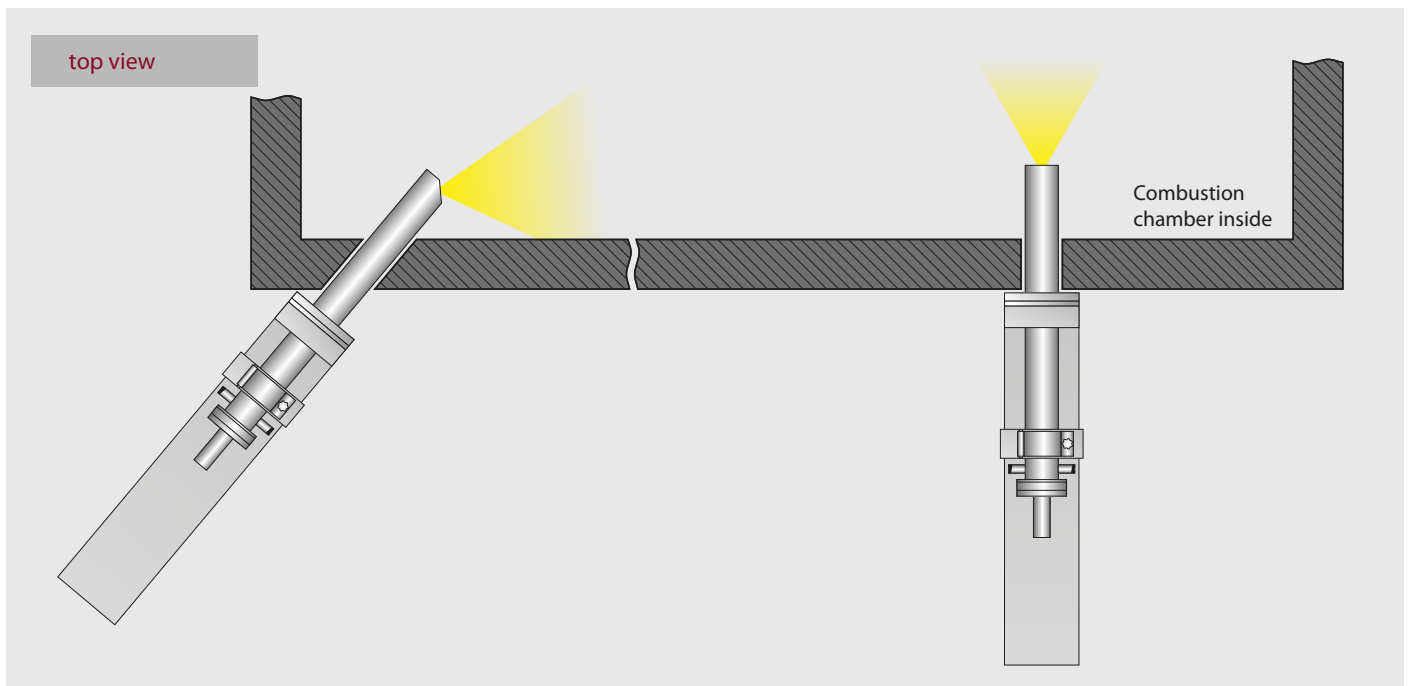

PIEPER

www.pieper-video.de
info@pieper-video.de

SCHWERTE

PIEPER GmbH
Binnerheide 33
58239 Schwerte

T: +49 2304 4701 0
F: +49 2304 4701 77

DÜSSELDORF

PIEPER GmbH
Gumbertstr. 111
40229 Düsseldorf

T: +49 211 2150 33
F: +49 211 2150 36

BERLIN

PIEPER GmbH
Großbeerenstr. 169
12277 Berlin

T: +49 30 722 52 99
F: +49 30 722 44 87

COTTBUS

PIEPER GmbH
Calauer Str. 70
03048 Cottbus

T: +49 355 430 903 40
F: +49 355 430 903 41